

2/2-way valves DN 8 to DN 50

For neutral gases and liquids

Solenoid actuated, with forced lifting

Piston valves

Internal threads G 1/4 to G 2 or 1/4 NPT to 2 NPT

Operating pressure 0 to 25 bar (40 bar)

85700

85710

Description (standard valve)

Solenoid valve for e. g. air, water, oil

Switching function:	normally closed
Flow direction:	determined
Fluid temperature:	-20 °C up to max. +90 °C
Ambient temperature:	-20 °C up to max. +50 °C
Mounting position:	optional, preferably solenoid vertical on top

Material

Body:	Brass (CW617N)
Seat seal:	NBR
Internal parts:	Stainless steel, PTFE/Carbon

For contaminated fluids insertion of a strainer is recommended.

Features

- High flow rate
- For robust industry solutions
- Damped operation
- Suitable for vacuum
- For systems with low or fluctuating pressure
- Valve operates without differential pressure
- Solenoid interchangeable without tools (**Click-on®**) up to G 1 thread
- Stainless steel piston

Symbol

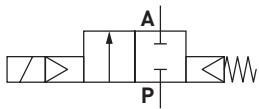

Ordering information

To order, quote model number from table overleaf, e. g. 8570400.9401 for a DN 25 valve.

Click-on®



Characteristic Data

Valves

Part Number Solenoid with 1	Part Number Solenoid with 2	Nominal Diameter (mm)	Connection Size	Operating Pressure *		kv-value ** (Base m³/h)	Weight Total (kg)
				min.	max. (bar)		
8570000.9401 8571000.9401	8570000.9404 8571000.9404	8	G 1/4 1/4 NPT	0	25	2.2	2.4
8570100.9401 8571100.9401	8570100.9404 8571100.9404	10	G 3/8 3/8 NPT	0	25	3.4	2.4
8570200.9401 8571200.9401	8570200.9404 8571200.9404	12	G 1/2 1/2 NPT	0	25	4.4	2.5
8570300.9401 8571300.9401	8570300.9404 8571300.9404	20	G 3/4 3/4 NPT	0	25	7.0	2.7
8570400.9401 8571400.9401	8570400.9404 8571400.9404	25	G 1 1 NPT	0	25	10.5	3.1
8570500.8401 8571500.8401	8570500.8404 8571500.8404	32	G 1 1/4 1 1/4 NPT	0	25	25.0	5.6
8570600.8401 8571600.8401	8570600.8404 8571600.8404	40	G 1 1/2 1 1/2 NPT	0	25	27.0	5.4
8570700.8401 8571700.8401	8570700.8404 8571700.8404	50	G 2 2 NPT	0	25	43.0	6.8

* for gases and liquid fluids up to 40 mm²/s (cSt)

State voltage [V] and frequency [Hz]

** C_v-value (US) ≈ kv-value x 1.2

Solenoid 9401 / 9404 and 8401 / 8404

Standard voltage

DC ≡	AC ~ 40 Hz – 60 Hz	
24 V	24 V	–
–	110 V	120 V
–	230 V	220 V

Design acc. to DIN VDE 0580

Voltage range ±10 %

100 % duty cycle

Protection class acc. to EN 60529 IP65

Socket Form A acc. to DIN EN 175301-803 (included)

AC with rectifier plug

Power Consumption

According to DIN VDE 0580 at coil temperature of +20 °C. In operation the power consumption of the solenoid decreases by approx. 30 %.

Solenoid	DC ≡	AC ~	
		Inrush	Holding
9401 *	38 W		
9404 *		42 VA	42 VA
8401	40 W		
8404		45 VA	45 VA

*  coil only

(with the exception of solenoid 94xx up to 41 V AC)



Attention!

The conditions imposed on the Ex approvals lead to reduction of the permissible standard temperature ranges in the cases of explosion protected solenoids.

Further Options (Valves)

- XXXXX01.XXXX Normally open, vertical on top, only with solenoid 8400
 - XXXXX02.XXXX Manual override
 - XXXXX03.XXXX Seat seal FPM, Fluid temperature –10 °C up to max. +110 °C 1)
 - XXXXX06.XXXX Seat seal PTFE, Fluid temperature max. + 110 °C 1), operating pressure max. 25 bar
 - XXXXX14.XXXX Seat seal EPDM, max. Fluid temperature +110 °C
 - XXXXX17.XXXX Normally open, Seat seal FPM, Fluid temperature –10 °C up to max. +110 °C 1), Mounting position: vertical on top, only with solenoid 8400
 - XXXXX22.XXXX max. operating pressure 40 bar
 - XXXXX23.XXXX Position indicator with two solenoid sensors, only with solenoid 8400
 - XXXXX25.XXXX Seat seal FPM, with larger bleed orifices in the piston, for fluids such as fuel and oil, viscosity max. 80 mm²/s (cSt), Fluid temperature –10 °C up to max. +110 °C
 - XXXXX92.XXXX Degreased version, suitable for oxygen operating, the BAM approval up to 25 bar for oxygen is available.
- On request Further versions

Further Options (Solenoids)

- XXXXXXXX.8441 Protection class  EEx me II T3 T 140 °C
- XXXXXXXX.9426* Protection class  EEx nA II T4 T 135 °C
- XXXXXXXX.8426* Protection class  EEx nA II T4 T 135 °C

On request Further versions

* DC only, for AC solenoids with design inspection certificate acc. to category 2, e. g. xxxxxx.8441

¹⁾ Up to max. 200 °C fluid temperature with solenoid for higher temperature

Section View

up to G 1 resp. 1 NPT

- 101 Valve body
- 102 Valve cover
- *103 Valve piston
- 104 Socket head cap screw
- *105 Pressure spring
- *106 O-ring
- *107 O-ring
- *108 Grooved ring
- 400 Solenoid
- 701 Core tube
- *702 Straight pin
- 703 Round plate
- *704 Pressure spring
- *705 Core
- 706 Spring clip
- *707 O-ring
- 1400 Socket (included)

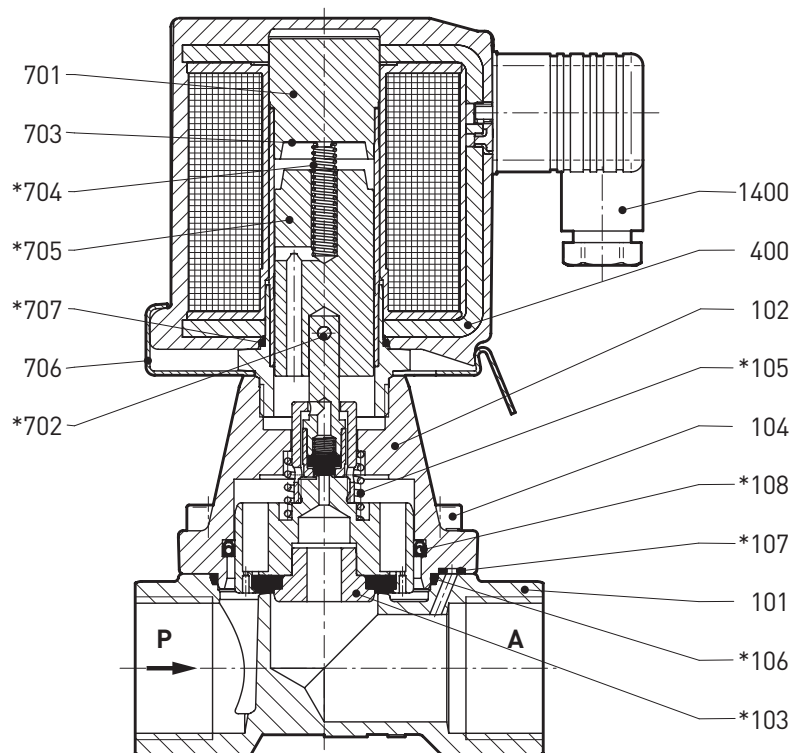

from G 1 1/4 resp. 1 1/4 NPT

- 101 Valve body
- 102 Valve cover
- *103 Valve piston
- 104 Socket head cap screw
- *105 Pressure spring [2x]
- *106 O-ring
- *107 O-ring
- *108 Grooved ring
- 400 Solenoid
- 701 Core tube
- *702 Straight pin
- 703 Round plate
- *704 Pressure spring
- *705 Core
- 1400 Socket (included)
- 1501 Hexagon screw
- 1502 Round plate
- *1504 O-ring [2x]

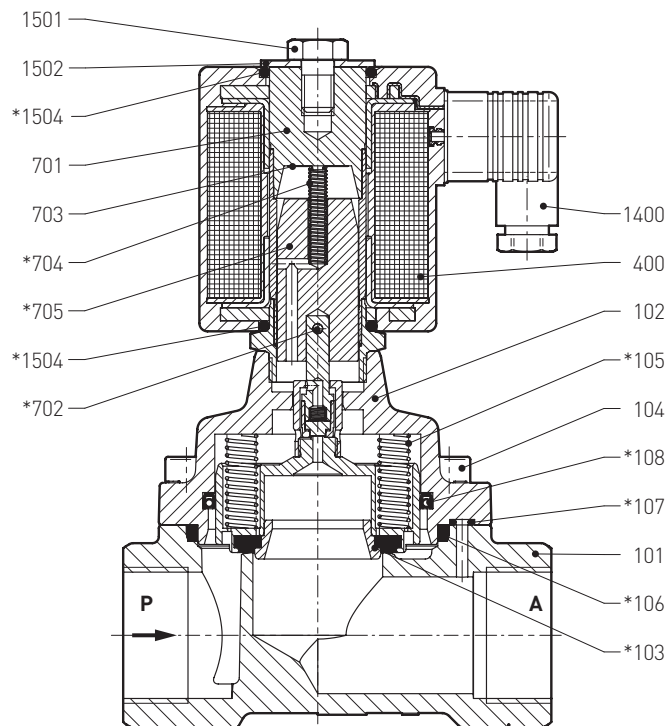

* These individual parts form a complete wearing unit.
When ordering spare parts please state Cat. No. and Series No.

General Dimensions

Solenoid rotatable 360°
 Socket turnable 4 x 90°
 (Socket included)

up to G 1 resp. 1 NPT

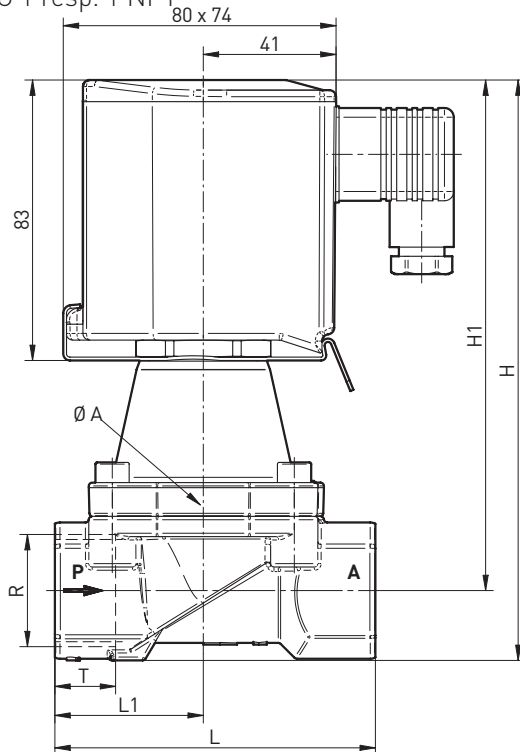

from G 1 1/4 rep. 1 1/4 NPT

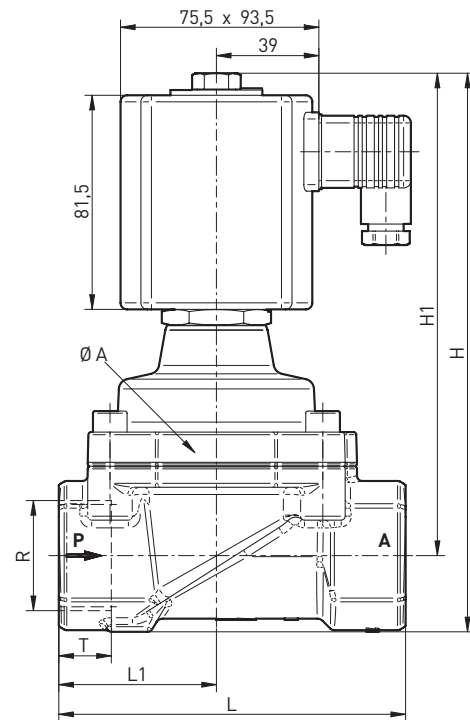

Part Number	Nominal Diameter (mm)	Connection Size	A (mm)	H (mm)	H 1 (mm)	L (mm)	L 1 (mm)	T (mm)
8570000.940x 8571000.940x	8	G 1/4 1/4 NPT	44	152.0	140.5	60	27.5	12.0 10.0
8570100.940x 8571100.940x	10	G 3/8 3/8 NPT	44	152.0	140.5	60	27.5	12.0 10.5
8570200.940x 8571200.940x	12	G 1/2 1/2 NPT	44	154.5	140.5	67	31.0	14.0 13.5
8570300.940x 8571300.940x	20	G 3/4 3/4 NPT	50	162.0	146.5	80	35.5	16.0 14.0
8570400.940x 8571400.940x	25	G 1 1 NPT	62	183.0	162.0	95	44.0	18.0 17.0
8570500.840x 8571500.840x	32	G 1 1/4 1 1/4 NPT	92	212.5	183.5	132	60.0	20.0 17.0
8570600.840x 8571600.840x	40	G 1 1/2 1 1/2 NPT	92	212.5	183.5	132	60.0	22.0 17.0
8570700.840x 8571700.840x	50	G 2 2 NPT	109	226.5	192.0	160	74.0	24.0 17.5

Note to Pressure Equipment Directive (PED):

The valves of this series, including the connection size DN 25 (G 1), are according to Art. 3 § 3 of the Pressure Equipment Directive (PED) 97/23/EG. This means interpretation and production are in accordance to engineers practice wellknown in the member countries.

The CE-sign at the valve refers not to the PED. Thus the declaration of conformity is not longer applicable for this directive.

For valves > DN 25 (G 1) Art. 3 § (1) No.1.4 applies.
 The basic requirements of the Enclosure I of the PED must be

fulfilled. The CE-sign at the valve includes the PED. A certificate of conformity of this directive will be available on request.

Note to Electromagnetic Compatibility Guideline (EEC):

The valves shall be provided with an electrical circuit which ensures the limits of the harmonised standards EN 61000-6-3 and EN 61000-6-1 are observed, and hence the requirements of the Electromagnetic Compatibility Guideline (2004/108/EG) satisfied.